

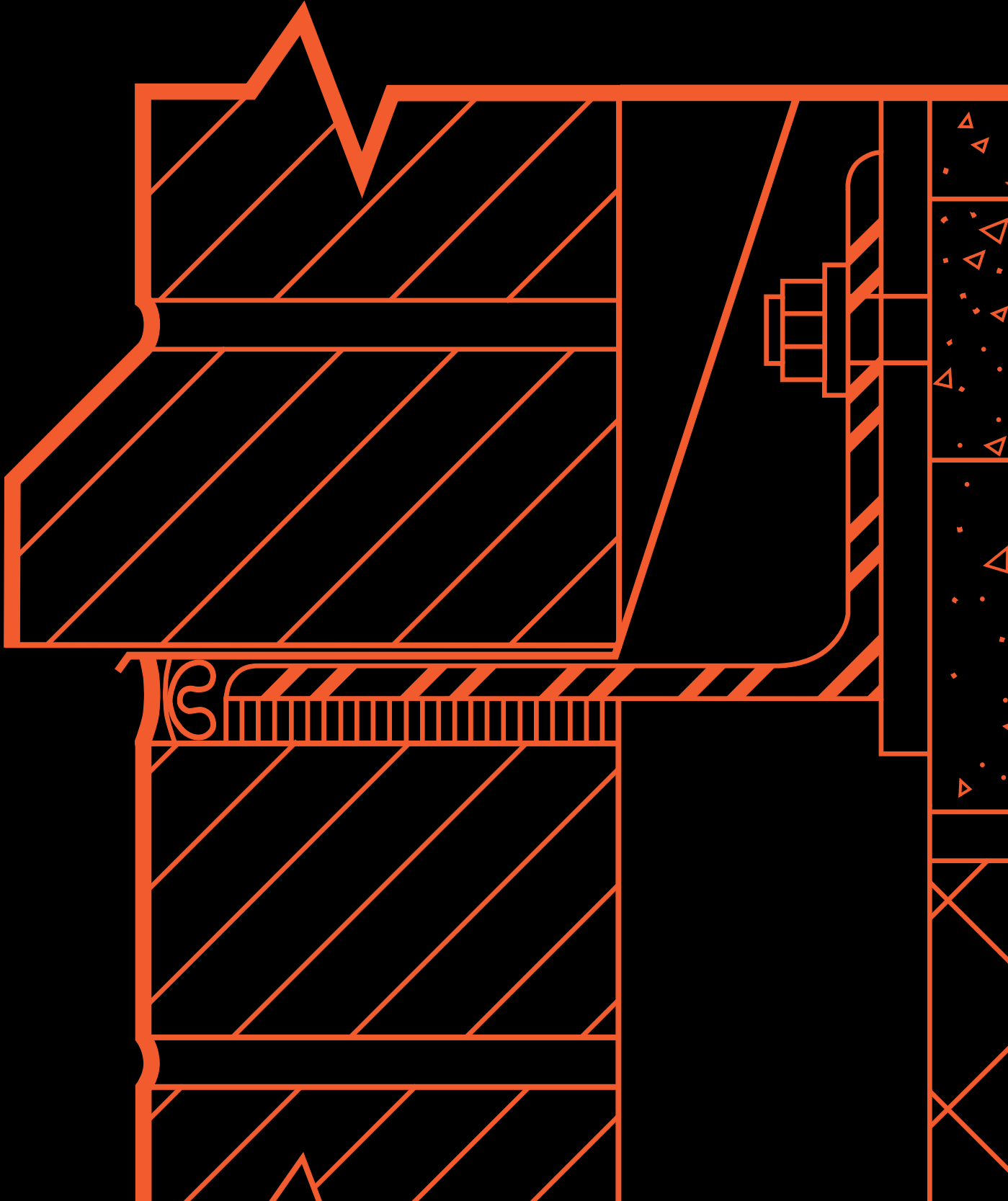

Glen-Gery's Brickwork Techniques Seminar Series:

"The Basics of Brickwork Details"





“The Basics of Brickwork Details”

CAUTION: This document is intended for use in conjunction with the Seminar Presentation: “BASICS OF BRICKWORK DETAILS.” Understanding many of the concepts and details presented in this document requires further explanation which is provided in the seminar. Also, the documents listed below provide additional information that should be understood before attempting to apply the information in this document to specific applications.

Reference List

1. Seminar: Basics of Brickwork Details

2. Brick Industry Association Technical Notes on Brick Construction:

(www.bia.org)

- #1 – All-Weather Construction
- #3 – Overview of Building Code Requirements for Masonry Structures
- #7 – Water Penetration Resistance – Design and Detailing
- #7A – Water Penetration Resistance – Materials
- #7B – Water Penetration Resistance – Construction and Workmanship
- #8 – Mortars for Brick Masonry
- #8B – Mortar for Brick Masonry – Selection and Controls
- #18 – Movement – Volume Changes and Effect of Movement, Part I
- #18A – Movement – Design and Detailing of Movement Joints, Part II
- #20 – Cleaning Brick Masonry
- #21C – Brick Masonry Cavity Walls – Detailing
- #23 – Efflorescence, Causes and Mechanisms, Part I of II
- #23A – Efflorescence, Prevention and Control, Part II of II
- #28 – Anchored Brick Veneer – Wood Frame Construction
- #28B – Brick Veneer/Steel Stud Walls
- #36 – Brick Masonry Details – Sills and Soffits
- #36A – Brick Masonry Details – Caps and Copings, Corbels and Racking

3. National Lime Association (www.lime.org)

Lime-Based Mortars Create Watertight Walls

4. The Masonry Society (www.masonrysociety.org)

TMS 402 Building Code Requirements for Masonry Structures

5. Glen-Gery Corporation (www.glengerybrick.com)

Brickwork Design Profile 4t1, Cleaning New Brickwork
Brickwork Design Profile 4t2, Masonry Construction Recommendations
Brickwork Design Profile 4p7, Glen-Gery Glazed Brick

6. ASTM, International

C 270, Standard Specification for Mortar for Unit Masonry

This publication is intended solely for use by professional personnel who are competent to evaluate the significance and limitations of the information provided herein, and who will accept total responsibility for the application of this information. To the extent permitted by law, Glen-Gery Corporation disclaims any and all responsibility for the accuracy and the application of the information contained in this publication.



PART ONE: Movement

There are four basic causes of movement in masonry materials:

1. CHANGES IN TEMPERATURE
2. CHANGES IN MOISTURE CONTENT
3. FREEZING EXPANSION
4. DEFLECTION:
Elastic and Plastic (creep)

THERMAL MOVEMENTS

Every material expands or contracts as the temperature of the material changes, typically expanding as its temperature increases and contracting as its temperature decreases. Different materials expand and contract at different rates when they undergo similar changes in their temperatures (**Figure 1**). When discussing wall systems, changes in the sizes of materials are of particular concern when they occur in the plane of the wall. When discussing wall systems, differing rates and directions of expansion or contraction of adjacent building materials are also of concern.

Brick veneer can expand and contract approximately 7/16" per 100 feet per 100° F temperature swing ($k_t = 0.000004$ inch per inch per °F). When calculating the expansion or contraction of a brick veneer using this factor, it is important to remember the effects of the sun on materials. The energy from the sun's rays raises the temperature of a material well above the air temperature: On a day when the air temperature is 32° F, the energy from the sun can raise a wall's temperature to above 100° F. **The temperature of the wall is what is important.** The sun can raise the temperature of dark materials to 160° F or more and lighter-colored materials to 120° F and these values should be used in design. Because a wall facing north or nearly so receives little or no sun in the Northern Hemisphere, the temperature of such a wall rarely exceeds the air temperature.

We often forget that buildings are rarely constructed at either 140° F or 0° F and that the amount of movement

THERMAL MOVEMENT OF BUILDING MATERIALS

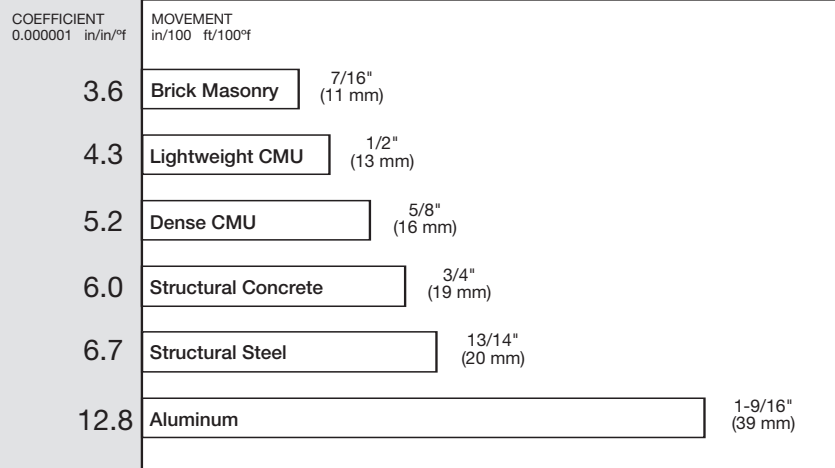

Figure 1

is not determined by the difference between the maximum temperature and the minimum temperature. In the case of expansion, the amount of movement is actually determined by the difference between the maximum temperature and the temperature of the wall when it was built. Similarly, in the case of contraction, the amount of movement is determined by the difference between the temperature at which the wall was built and the minimum temperature.

MOISTURE MOVEMENTS

Moisture affects all porous masonry materials, including brick, mortar, concrete masonry units, and stone, but in very different ways. These effects must be considered when a combination of these materials is used, such as when brick rests on a concrete foundation, brick veneer units are used with block back up, and when brick and architectural concrete products are used in the same wythe – bands of precast concrete or architectural concrete block in a brick veneer.

After their initial mixing or casting, mortar, poured-in-place concrete, and concrete masonry units shrink as the curing of the Portland cement proceeds. This is an unavoidable consequence of the curing of concrete products and is accommodated in design.

Mortar, concrete, and concrete masonry units also exhibit relatively major shrinkage movements as they dry during and immediately following construction. If, after initial drying, materials containing Portland cement concrete become wet, they will expand. As they dry again, they will shrink.

Brick masonry, on the other hand, does not shrink as it cures and dries in the wall. Brick masonry has an initial moisture expansion that is not reversible, just as is the shrinkage of concrete products as they cure is not reversible. As with concrete products, this change in size is accommodated in design. This expansion occurs as completely dry brick (typically fired in excess of 1800° F) are exposed to the moisture (humidity) in the air outside the kiln. Some brick expand more than others during this period. Many expand so little that the expansion is insignificant. Most moisture expansion occurs during the first two months after leaving the kiln. For most design purposes, a factor of moisture expansion of $k_e = 0.0005$ inch per inch may be used. As the moisture expansion of brickwork is in the opposite direction of the drying shrinkage of concrete or CMU, the differential movement may be significant. Composite masonry sometimes fails to perform properly because of these opposing movements. When composite systems are



used, the placement of movement joints in the brick and control joints in the concrete or CMU must receive additional attention.

Joint reinforcement is typically placed in the bed joints of concrete masonry to help control shrinkage cracking. If joint reinforcement and control joints are placed properly, cracking should be limited to the control joints. This reinforcement can be either the “truss” type or the “ladder” type. Truss-type 3-wire reinforcement, which has the third wire in the brick masonry bed joints, should not be used unless the wall system is designed as a composite wall with a grouted collar joint. In cavity or veneer wall systems, truss-type reinforcement can transfer forces to the brick wythe, forces which may cause damage to the mortar joints or loss of embedment of the wire. Note that ANY three-wire system may cause difficulties when laying the two wythes if one wythe is completed before the other; therefore, the “eye and pintle” system is preferred (**Figure 2**). If brick is laid in stack bond, horizontal joint reinforcing must be placed in the bed joints of the brick wythe to inhibit cracking of the continuous (vertical) head joints.

FREEZING EXPANSION

Freezing expansion occurs when clay masonry units saturated with water are frozen and the temperature of the frozen, saturated units goes below 14° F. The coefficient of freezing expansion is $k_f = 0.002$ inch per inch, but, since proper design does not allow masonry to become saturated, the coefficient of freezing expansion is usually not included in the design equations.

DEFLECTION

The sum of the elastic deflection and the plastic deflection of members supporting masonry must be limited to the lesser of 0.30" or $L/600$.

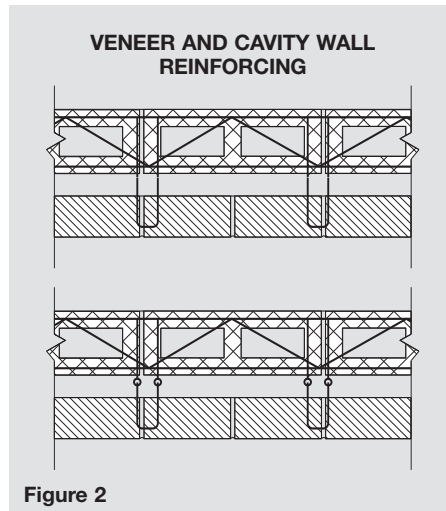

Figure 2

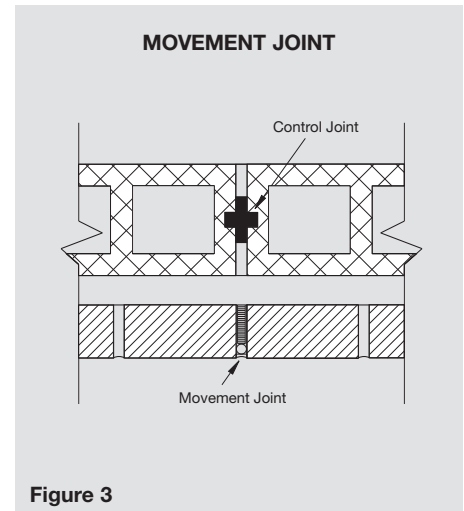

Figure 3

CALCULATING THE AMOUNT OF MOVEMENT

Actually, we are not really interested in the amount of movement! Rather, because the widths of movement joints are usually arbitrarily set, we are interested in determining how far apart the movement joints should be placed.

Brick Industry Association Tech Note 18A addresses movement joint spacing with this equation:

$$S = [w \cdot e] \div [k_e + k_f + k_t \Delta T]$$

Where,

- S** = spacing between adjacent joints in inches
- w** = width of the movement joint in inches
- e** = extensibility or compressibility of the sealant/filler
- k_e** = coefficient of moisture expansion, in./in.
- k_f** = coefficient of freezing expansion, in./in. (Usually ignored)
- k_t** = coefficient of thermal expansion, in./in./°F
- ΔT** = change in temperature of the brickwork, °F

There are at least two conditions that must be checked; the temperature change between the construction temperature up to maximum wall temperature and the temperature change between the construction temperature down to minimum wall temperature.

MOVEMENT JOINTS

Movement joints in the brickwork should be placed at regular intervals in the structure to help prevent large

tensile, compressive, or shear stresses from developing. If large stresses are not generated, cracks cannot occur. A movement joint is a discontinuity in the structure – a break in the fabric of the building – that allows movement to occur and prevents the build-up of stresses. In most brick veneer structures, the only evidence of a movement joint is a very thin vertical or horizontal band at the face of the wall. The exposed portion of this band is usually an elastomeric sealant which prevents rain, snow, debris, and small plants and animals from filling the movement space or entering the structure.

One of the decisions that the designer must make is how wide this band may be without unduly disturbing the eye. Usually, designers limit the widths of the joints to 3/8" to 1/2", about the width of the mortar joints surrounding the movement joint. This decision is a key ingredient in the equation used to calculate the spacing of movement joints. To a degree, wider joints allow greater spacing between joints and narrower joints require closer spacing of joints. Movement joints more than 3/4" wide are not recommended.

In most building construction a movement joint must include a sealant, a backer rod, and a compressible filler material. Always use sealants which are capable of accommodating the calculated movement without failing. These sealants should comply with the requirements of ASTM C 920. Check with your sealant suppliers for their recommendations, as some very pop-



ular construction sealants do not bond well to masonry products. Be sure to take into account all materials to which the sealant must bond (i.e., brick, concrete, window frames, flashings, shelf angles or metal caps) since some must be primed before certain sealants are applied. Sealants generally perform best when the ratio between the width of the sealant and its depth is about 2:1. Beads of sealant applied in a fillet or butt configuration have a much reduced service life.

A backer rod must be present to support the sealant during installation and tooling while also providing a bond break between the sealant and compressible filler. Backer rods may not be necessary if the sealant does not bond to the compressible filler and the filler provides adequate support for the sealant. Backer rods are usually smooth, closed cell foam ropes that are larger than the joint and which are forced into place before the sealant is installed. Compressible fillers are installed to keep mortar or other material from filling the joint. The compressible filler may be installed during construction to prevent mortar from filling the joint during brick laying and reducing the movement capacity of the joint. These fillers must have a compressibility equal or greater than the maximum compressibility of the sealant, which is generally no greater than 50%. Many filler materials are available, including premolded rubber and plastic.

HORIZONTAL MOVEMENTS

When the cyclical movements associated with horizontal expansion and contraction have not been considered during design, corners are particularly susceptible to cracking caused by tensile and shearing stresses. **Figure 4** shows what can happen when the brick veneer expands – a crack develops at the corner.

Cracks may also develop at windows, doors, changes in cross section, or other weak points in the masonry. The effects of cyclical movements are magnified when the brick are laid in stack bond because the tensile bond between the mortar and the brick is not great; much of the strength of a wall comes from the

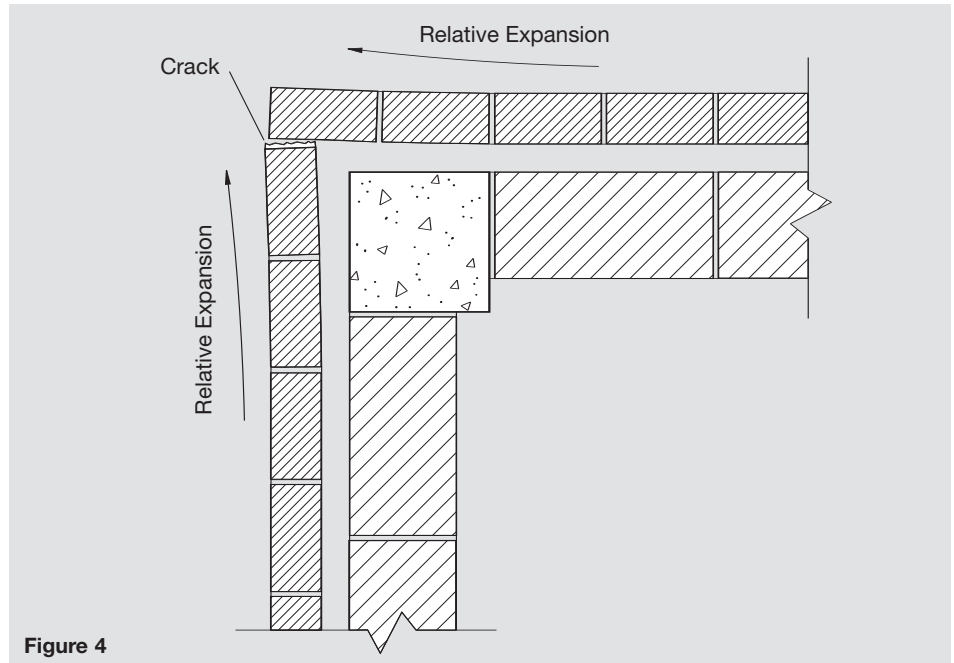

Figure 4

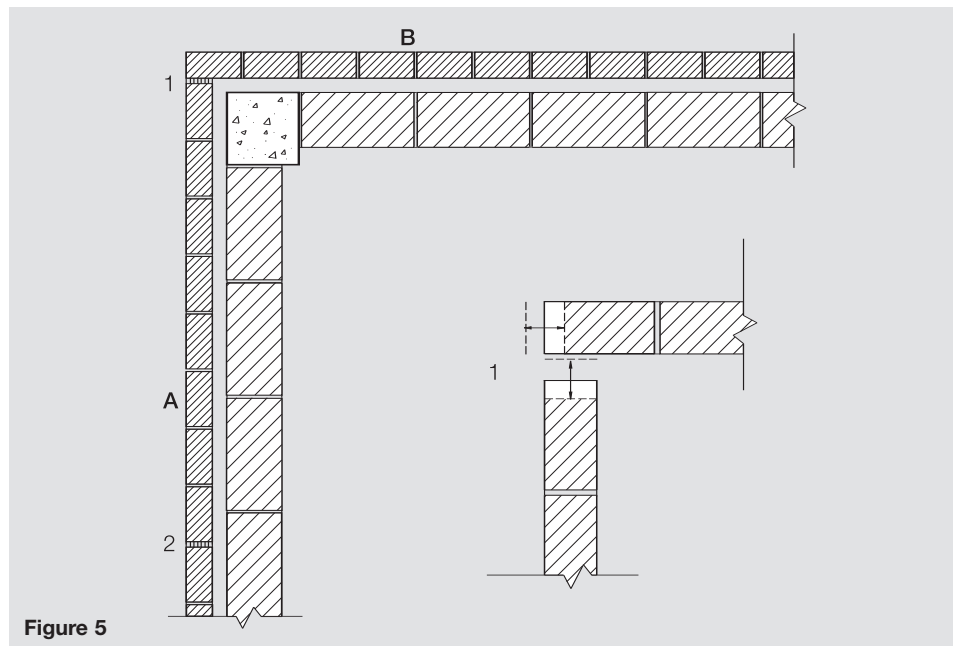

Figure 5

interleaving of brick resulting from staggered head joints. In stack bond work, poor tensile bond strength must be overcome by installing continuous reinforcement at no more than 18 inches on centers, vertically, in the bed joints of the brick masonry as per ACI 530 and other building Codes. This technique is also effective whenever tensile strength must be increased, regardless of the bond pattern.

Since expansion cracks often occur near corners, one logical location for a movement joint is at the first head joint from a corner (Point #1 in **Figure 5**). Unless they are installed as a remedial measure, movement joints are rarely found at corners, primarily for aesthetic reasons. They are usually placed two to ten feet from the corner (Point #2 in **Figure 5**), where, in buildings with shelf angles, the movement joint may coincide with the window jambs to help to disguise the presence of the



joint. When the veneer is supported on shelf angles, vertical movement joints may be placed virtually anywhere the designer decides that they are needed because the horizontal movement joints at the shelf angles divide the facade into relatively small, discrete, regular sections.

If the masonry is carried across openings by lintels, it is best to avoid placing vertical movement joint at the jambs of the openings. Instead, place them several feet from the jambs. Although movement joints are often placed at the jambs with no ill effect – this detailing “works” – more conservative design suggests placing the movement joints well away from jamb lines and the ends of the lintels.

Do not place vertical movement joints at the end of lintels.

Another critical point for crack control is at offsets in walls, such as at A in **Figure 6**. Since A is short and rigid, it can easily be cracked by the rotational effect caused by the movement of the two long walls. A movement joint should be placed at the inside corner. The only time this is not true is when the next movement joint in each long wall is less than 10 feet from the corner.

Long sections of masonry with punched openings with heads supported by lintels should include vertical movement joints to guard against shear cracks forming at the top corners of windows (**Figure 7**) or diagonal cracks forming at piers. Stresses develop as the masonry below the windows, which is restrained from moving by the presence of the foundation, expands and contracts less than masonry above the windows. As the band of masonry above the openings is much longer than the bands of masonry between the openings, the total expansion is much greater and shear stresses are generated. These stresses are relieved when the crack forms. Remember, if lintels span the heads of the windows, the movement joints should not coincide with the window jambs.

Where adjacent sections of a wall differ in height and cross-section, the sections will respond to changes in

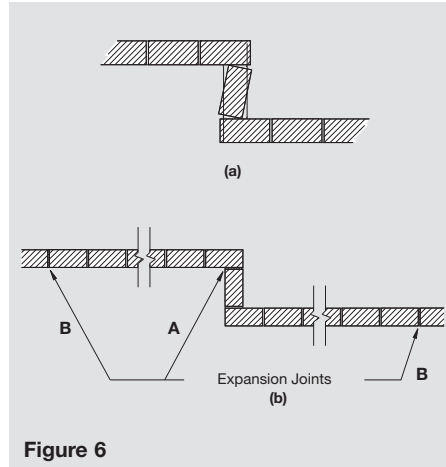

Figure 6

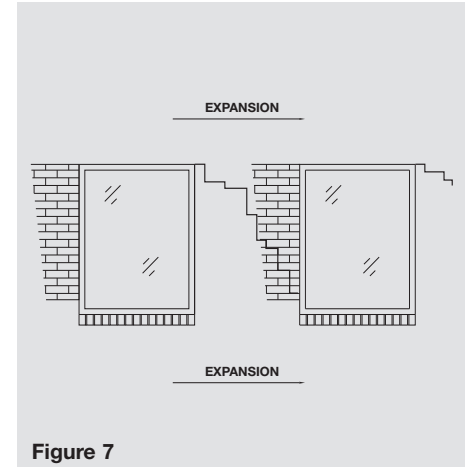

Figure 7

temperature at different rates because thinner, shorter sections will warm faster than taller thicker sections. To reduce the likelihood of cracking, movement joints are placed at the point where the cross-section of the wall changes (**Figure 8**).

In steel or concrete frame structures, one typical movement joint location is at a column. This location is not always necessary but may be helpful to the contractor. The brick veneer must be anchored to the column in such a way to allow vertical and horizontal movements and to allow the movement joint to function. One method is shown in **Figure 9**. Since the ties between the veneer and the back-up transfer wind forces

to the back-up, the back-up system must also be tied to the columns in a manner which transfers wind loads while allowing vertical movement to occur. Construction tolerances are rather fluid and the attachment of the veneer to the column at a movement joint should include a tie for the end of each veneer panel.

Although movement joints in brick veneer and control joints in the block back up may align, it is not necessary for them to do so, and they can be placed where ever the design dictates. One advantage of aligning the two joints is that it may make construction and inspection easier.

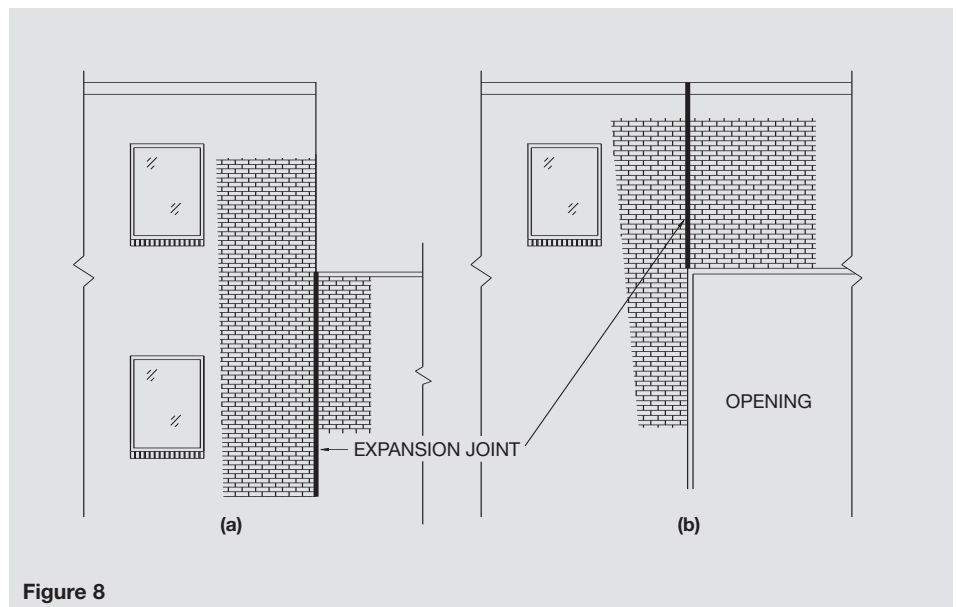

Figure 8



VERTICAL MOVEMENTS (Elastic and plastic deflections)

As mentioned earlier, movements occur in the vertical direction as well as the horizontal, but while horizontal wall segments tend to move at both ends from a stationary midpoint, vertical wall segments expand upward from relatively stationary supports and contract downward toward these supports. Many building codes limit the vertical spans of brick veneer to 30 feet or less. The practice of supporting brick veneer on shelf angles at each floor level requires the installation of movement joints beneath each shelf angle. The shelf angles themselves should be sized and anchored to carry imposed loads such that total displacement of the toe of the angle is limited to $L/600$ or 0.3", whichever is less.

One detail for a supporting shelf angle is shown in **Figure 10**. The expansion gap size is dictated by the total amount of movement caused by:

1. Thermal expansion and contraction of the veneer below.
2. Moisture expansion of the brickwork below.
3. Freezing expansion of the brickwork below.
4. Elastic deflections of the shelf angle, supporting beam, spandrel, slab edge and columns.
5. Plastic deflections (creep) of vertical members, particularly in concrete masonry and reinforced concrete buildings.
6. Thermal frame movements.

Note: A steel frame erected at 80° F will shrink substantially if exposed to 30° temperatures in the winter.

Creep is the continuing shortening of a member under constant loading – a plastic deformation. Creep usually occurs over a relatively long period of time. When Portland cement concrete products, which are particularly prone to creep, are fully cured, members loaded in compression actually squeeze or flow together. The speed of this flow is greatest at first, and continues, but at a decreasing rate, for several years. The total amount of creep depends on the concrete

strength, the intensity and duration of loading, and the size of the member.

As an example, if we assume that a 10 story building with 10 feet story heights has a creep value of 0.05" per floor, the total creep would be 0.5". If there were shelf angles supporting brick veneer at every floor level, the expansion gap under each shelf angle will close permanently by 0.05" (almost 1/16"). Added to other movements, this shrinkage reduces the serviceability of the structure if not considered during design. If shelf angles are placed every three stories (30 feet), then each gap would close by 0.15" (more than 1/8") from column shortening alone. Creep also affects concrete beam deflections, which are in addition to the column shortening.

MOVEMENT JOINT AT COLUMN

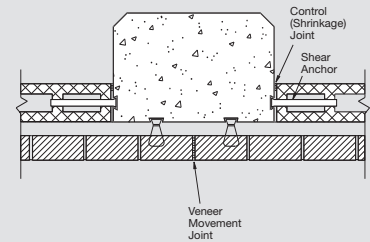

Figure 9

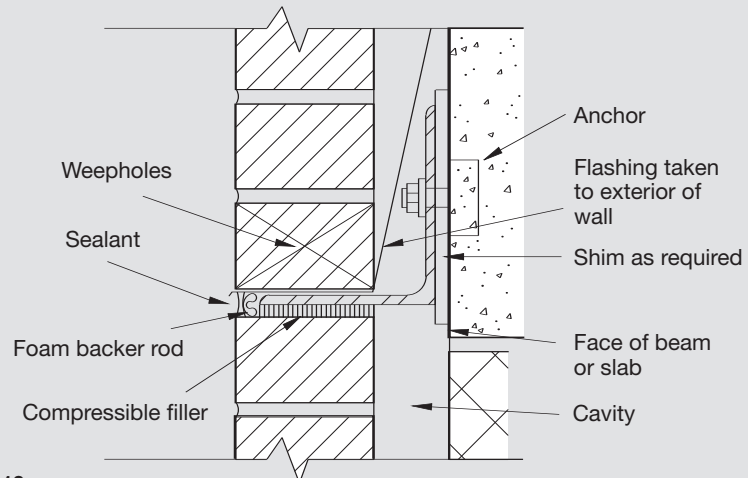

Figure 10

SPECIAL SHELF ANGLE UNITS

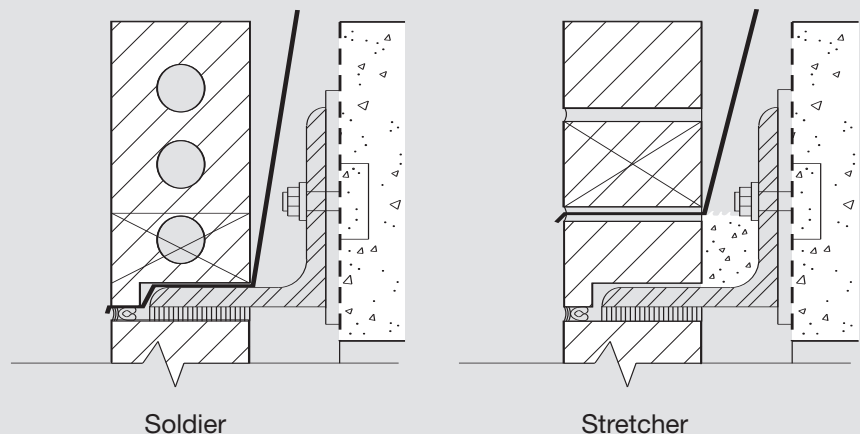

Figure 11



SHELF ANGLES AND LINTELS

While both are usually formed with hot-rolled steel angles, shelf angles and lintels are very different. In both cases the weight of the masonry veneer above the steel angle bears on the angle. When a lintel is used, the weight of this masonry is transferred to the jambs of the opening below the lintel. Shelf angles act in a different way: Shelf angles do not rest on the jambs of the openings below, they are attached to the building frame. Thus the weight of the masonry above a shelf angle is transferred the building frame and the masonry in the jambs of the opening below carry no load other than the weight of the jamb itself.

LIPPED BRICK

When all of the vertical movements are taken into account, the movement gap at each shelf angle is usually about 1/2 inch thick (tall) when built. The shelf angle is 7/16 inch or 1/2 inch thick. Thus, the thickness of the horizontal joint at the shelf angle is an inch or more thick. Although the movements discussed may narrow this gap somewhat, the gap is wider than corresponding bed joints and is visually objectionable. Special shelf units (lipped brick) detailed in **Figure 11** can eliminate this objection (Note that, in most instances, lipped brick cannot be used with lintels). Remember that special lipped corner brick are needed at corners. Extending the flashing to the face of the brickwork is difficult when lipped brick are used and some designers turn the lipped brick upside down to allow easier placement of the flashing. This practice should be avoided since the lip is very close to the toe of the shelf angle and contact may damage the brick. Another option is to place the flashing and weepholes in the mortar joint above the first course of brick resting on the shelf angle. If this option is used the space between the angle and the flashing should be filled with mortar to support the flashing and prevent collection of water.

Glen-Gery makes lipped brick to match both molded and extruded brick. Lipped brick should not be field

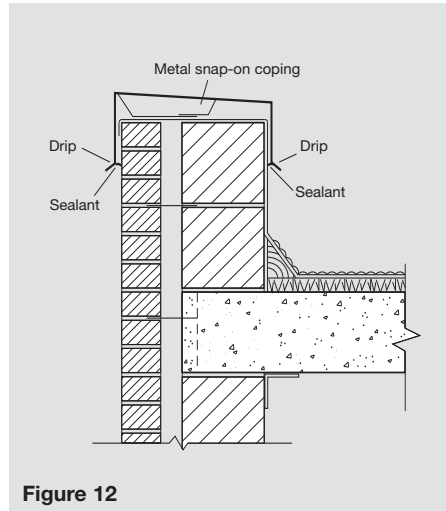

Figure 12

cut since over-cutting in either direction creates a weak point in the brick which may result in cracking the lip itself. Also, corner brick cannot be cut in the field unless a mitered corner is acceptable. The presence of the shelf angle may also be disguised by corbeling the course of brick immediately above the angle to create a shadow line.

PARAPETS

Parapets require special consideration because they are exposed to more environmental changes – temperature changes, wind loads, and rain and snow – than the walls below. Both the magnitude and the rate of change of the environmental factors are greater for parapet walls than for the walls below. Also, the direction of change may be very different. Therefore, vertical movement joints in the parapet should be no more than 20 feet apart unless each masonry wythe is reinforced. Corners and offsets remain critical locations that must be protected. **Figures 12 and 13** show several suggested details concerning proper parapet wall design. Note that these figures do not show all elements of either detail.

Figures 12 and 13 show an air space which is continuous past the roof edge. This eliminates a shelf angle and reduces the likelihood of efflorescence and staining. The vertical legs of metal caps should cover at least four inches of the masonry. The metal coping shown in **Figure 12** forms an impervious cap which is considered an

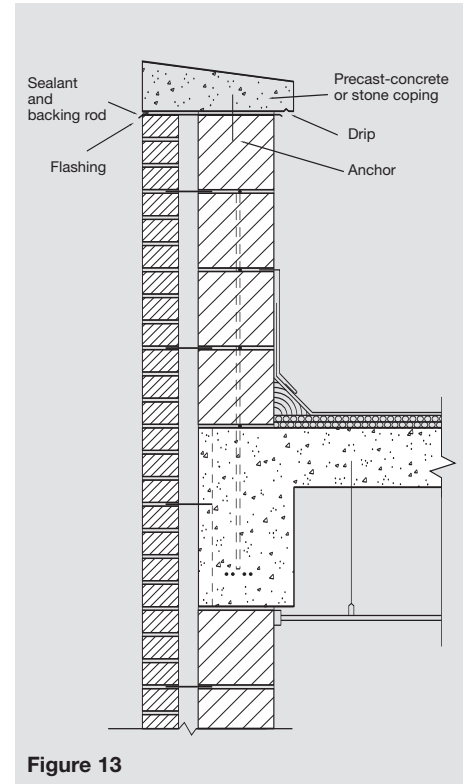

Figure 13

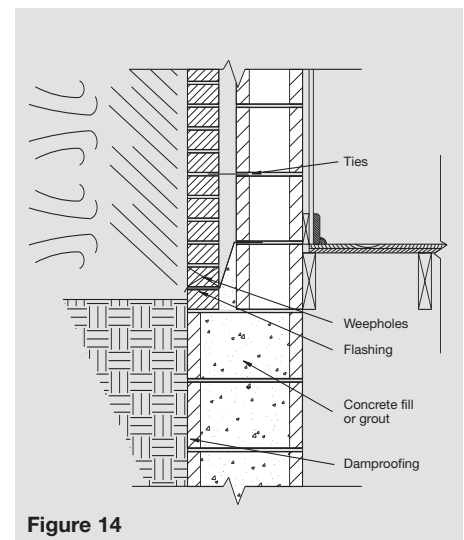

Figure 14

external flashing. Masonry copings tend to be more susceptible to water penetration, require through-wall flashing, and may require more maintenance because of reliance upon sealants in movement joints between adjacent members. Note that covering the exposed face of the backup with an impervious membrane for the entire height of the back-up wythe may trap moisture within the back-up wythe and



reduce the durability of both the masonry and the impervious membrane. If a membrane does cover the back-up wythe, the height of the parapet should be no more than 16".

Other coping materials can be used with these systems. Cast stone, concrete, natural building stones, terra cotta and brick must be laid with a flashing, must be anchored to the structural back-up, and must have a soft joint placed between the bottom of the coping and the top of the brick veneer. Always separate veneers from elements rigidly attached to the back-up system. Through-wall flashings are required not only because these copings are permeable, but because the many joints of these copings may deteriorate and fail, allowing moisture penetration. Masonry copings should incorporate the largest units available to limit the number of joints at the top of the wall and thus the likelihood of moisture penetration. The mortar joints between large rigid caps such as stone or concrete should be raked and caulked to reduce potential moisture penetration at bond breaks. Flashing should be installed immediately below the cap. The cap should include a minimum 15° slope and, on the low side, project past the face of the wall below with a drip a minimum of 1" from the face of the wall. Stone, concrete, and cast stone copings may contain soluble components which, in the absence of a flashing under the coping, may stain the masonry below.

PART TWO: WATER PENETRATION

For most of our history, brick masonry has been used as a structural material, laid in multiple, tied wythes to provide the major support for the floors and roof of a structure. Only in this century has this changed; the use of reinforced concrete and steel framing has eliminated the need for load-bearing brick masonry and we commonly use only a single wythe of brick masonry to clad buildings. Multiple-wythe brick masonry is water resistant because of its great mass. It must rain very hard for a very long time before 12" or 16" or 24" of brick masonry can

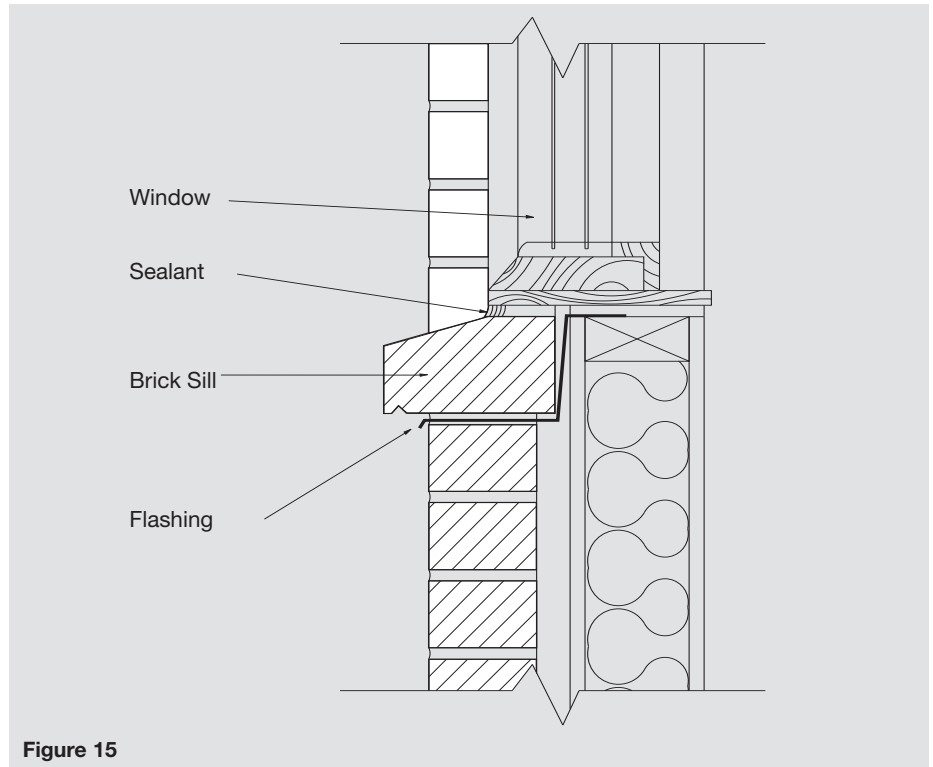

Figure 15

be so saturated with water that the water appears inside of the structure. Four inches of brick masonry, the usual nominal thickness of a brick veneer, will not keep the water out all of the time; the mass of masonry is not so great that it can absorb all of the water to which it is exposed before penetration through the brick wythe occurs.

Designers have long recognized this characteristic of single-wythe veneers and have developed the "drainage wall" system to accommodate it. The concept of the drainage wall is relatively simple (Figure 14): A space is maintained between the back of the brick wythe and the face of the back-up material so that water which penetrates the veneer **cannot** reach the back-up system. As there are places where there are paths to the back-up system, at shelf angles and at the bases of walls, for instance, a flashing is installed to collect water at these places. So water does not fill up the air space (cavity), weepholes are placed on top of the flashing at the base of the air space to drain water from the wall. Critical to the performance of this system is maintaining a clear space between the back of the brick wythe and the face of the back-up system or

the face of any insulation or other materials applied to the face of the back-up.

A further development of the drainage wall system is the rain screen wall. Water may be driven through brick masonry because there is an air pressure difference between the two sides of the brick wythe. If there is no air pressure difference, very little water will pass through the masonry. In a rain screen system, the air space is vented at the top and bottom and horizontally compartmentalized to allow any differences in pressure to be equalized quickly. Once pressure differences are eliminated little water will pass through a properly designed and constructed brick wythe. Rainscreen walls are very specialized in both design and construction and are beyond the scope of this publication.

DESIGN AND SPECIFICATION OF DRAINAGE WALLS

One of the most effective methods of reducing the amount of water that hits a masonry wall is to use overhangs to protect the walls. This is particularly easy when pitched roofs are used. Gutters and downspouts



should be installed where other means of roof drainage have not been detailed. When the roof is flat, overhangs can be incorporated by extending the ends of the joists, but a more typical detail is a gravel stop or parapet wall. When a gravel stop is used, it is important that the gravel stop be high enough to retain water on the roof until it can drain off through the roof drains.

Parapet walls (and garden walls) must be capped to close the top of the wall. While brick masonry caps are very attractive, they present many opportunities for leakage and deterioration unless they are designed and installed very carefully. Masonry caps must be pitched to drain, have full joints, and be securely anchored to the wall below. A flashing and adequate anchoring system must be placed below masonry caps (**Figure 13**). In addition, a minimum 1" overhang and drip notches are recommended for all masonry caps. Glazed brick must not be used to form a cap.

When a metal cap is used,

- 1) the top must be pitched to drain,
- 2) the vertical legs of the cap must cover at least four inches of brick masonry, and
- 3) a drip must be formed at the bottoms of the vertical legs (**Figure 12**).

The primary function of a window sill is to keep water draining from windows or other impervious materials from running down the face of the masonry. Many other siding materials as well as windows and doors absorb little or no water, allowing most of the water to flow over the sill or cap below. All sills must have a minimum pitch of 15° (about 1/4" to the inch), must incorporate a drip edge or notch and should have as few joints as possible. Wind pressure on flat sills tends to increase water penetration, leading to deterioration of the sill or surrounding materials. Because of the absence of sunlight on north elevations, very deep sills receiving large amounts of water will remain wet, promoting organic growth and the accretion of dirt. As with wall caps, a flashing must be placed under all sills (**Figure 15**).

It is important to pitch the grade around the structure so that surface

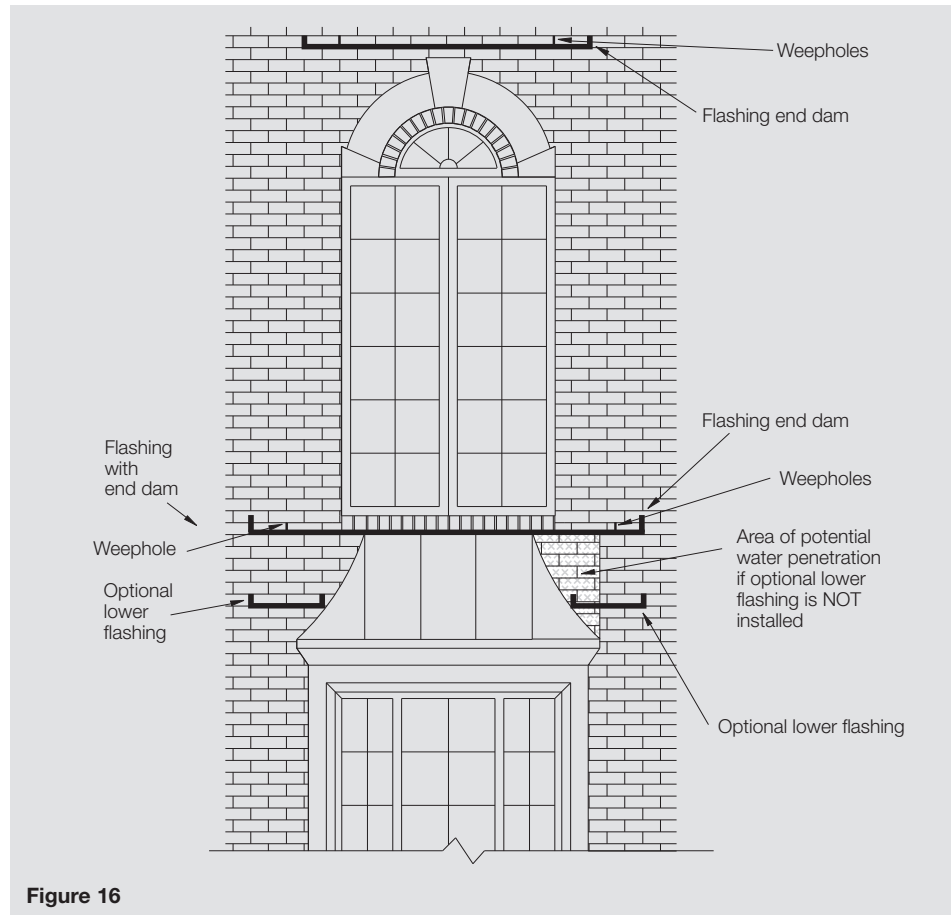

water is directed away from the building. Down spouts should not be discharged at the base of the wall, but, at a minimum, should be directed onto splash blocks and away from the building.

The key to the drainage wall system is to keep water from moving from the back of the veneer to the face of the back-up. The space between the veneer and the back-up – the air space – must be kept clear of mortar and other debris so that water has no path from the veneer to the inside of the structure. Wider air spaces, two inches, for instance, are easier to keep clean than narrower spaces and are recommended by many authorities. One way to keep the air space clean is by clearing the mortar droppings from the cavity by placing a board in the cavity and drawing it out as each tie location is reached. Spreading the mortar so that the inside of the bed is thinner than the outside will reduce the volume of mortar droppings. Proprietary systems are also available to help maintain a clear air space.

FLASHINGS

Changes in the details of the wall cross-section often allow materials to bridge the air space, providing a pathway for water to reach the interior of the building. This routinely occurs at shelf angles, lintels, load-bearing floor slabs, and at grade. To prevent this flow of water, a flashing, a flexible, impermeable material, is installed. The flashing both collects water and protects materials behind and below it from this water (**Figure 14**). Counter flashings, flashings under caps, and flashings under sills pr

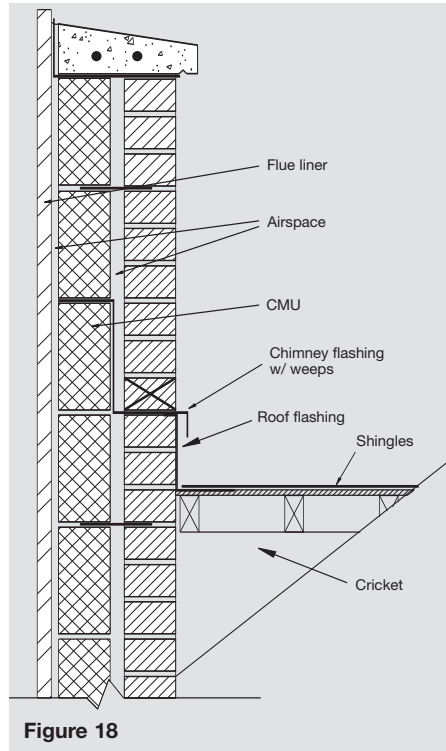
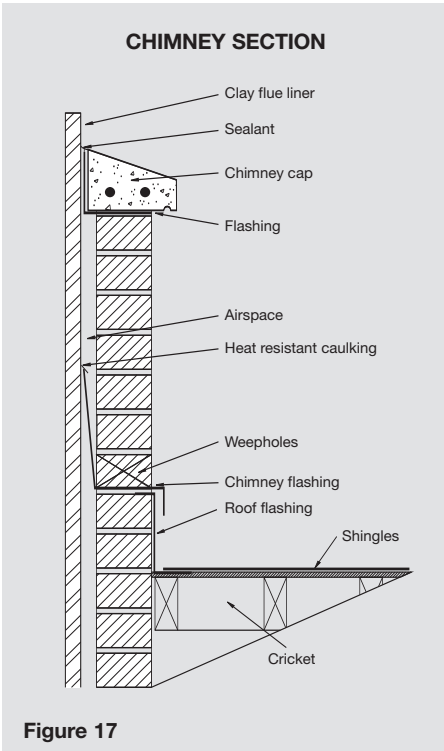

remain so. Because the basic materials and fabrication are so expensive, these materials are now little used. Most of the flashings installed today are plastics, fabric composites, and composite metal flashings. A very common flashing material that should be avoided is PVC (poly-vinyl-chloride). PVC flashings have a limited life span, as short as five years in a wall system that is expected to last for many years. Other materials, such as bitumen polymers, EPDM, fabric composites, or thin metal composites with cores of either aluminum or, preferably, copper, are preferred. Neither #15 or #30 building felt nor polyethylene sheeting may be used for flashings.

Although most flashing details will show the flashing forming a drip at the face of the wall, this is only possible if one of the rigid flashings is used. Plastics, composites, and thin metal composites cannot be formed into a drip and are difficult to hold in a straight line. One popular option is to require the mason to extend the flashing beyond the face of the wall and then cut it flush to the face of the wall. The details of many flashing manufacturers indicate that the flashing should be held behind the face of the wall about one-half inch. When this is done, the water will run under the flashing and into the core holes or back into the wall. Avoid these details.

Continuous flashings, such as occur at shelf angles and at the bases of walls, must be lapped and sealed in accordance with the flashing manufacturer's instructions. This often involves the use of a special mastic or adhesive. Do not use roofing cement. Care must be taken at inside and outside corners to insure that water cannot bypass the flashing and enter the wall system. Discontinuous flashings, such as those over a lintel, should extend beyond the end of the lintel. The ends of discontinuous flashings must be turned up into a head joint, forming a dam to prevent water from running from the end of the flashing and back into the wall (See **Figures 16 and 20**).

Flashings above curved arches or pitched roofs are often omitted because there is no obvious way to install the flashings. One practical method is to install short lengths of

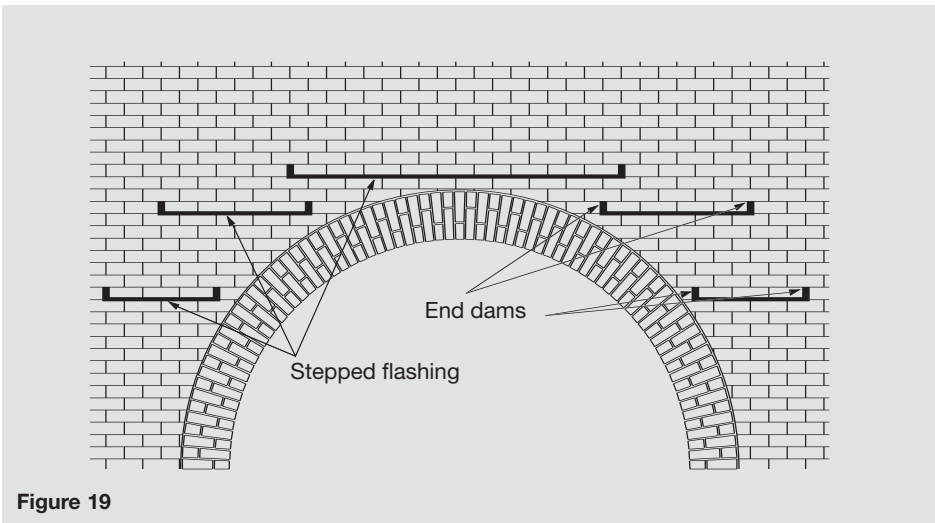

flashings laid in or attached to the back-up which then drop down at least eight inches, run horizontally, and then pass through or under the brick wythe to the outside.

Flashings in masonry above stepped roofs, above bay windows, and around chimneys are often attached to the face of the wall with a reglet. Flashing systems in these locations must include through-wall flashings that collect water from behind the brick wythe (**Figures 17 and 18**).

Rigid flashings for single wythe chimneys can be formed with short overlapping flashings. Flashings in multi-wythe chimneys must incorporate flashings which terminate in the back-up. Flashings from the face of the chimney to the roof may be attached to the face of the chimney or tucked below the through-wall flashing (**Figures 17 and 18**).

Traditionally, heavy copper, lead-coated copper, and stainless steel were the materials of choice and they



through-wall flashing above and along the line of the arch or lower roof. Each flashing has end dams and the upper flashings overlap and shield those below, protecting the building (See **Figure 19**). A single level of flashing can also be used successfully if the area of masonry between the flashing and the arch is small.

WEEPHOLES

Weepholes provide a path out of the wall for the water collected by the flashings. The easiest way to form a weephole is to space open head joints 24" apart, directly on top of the flashings. Weepholes located a course or more above the flashings are of little benefit. Many designers do not like the shadow created by using open head joints for weepholes and a number of vents, screens, and multi-celled devices are available to disguise the presence of these weepholes. All of these may be spaced 24" apart. Cotton wicks – not nylon or other synthetics, they do not “wick” – may also be used. Three-eighth inch cotton clothesline works well, particularly when draped over the first set of ties above the flashing. Wicks should be spaced no more than 16" apart. Do not use 3/8" plastic tubes; they are easily clogged during construction. Some designers and contractors placed two to four inches of unbroken pea gravel at shelf angles, at lintels, and at the base of the cavity to prevent weepholes from being clogged by mortar droppings. This can be an effective technique unless the volume of mortar droppings is such that a continuous barrier of mortar is formed on top of the gravel, or mortar dropping on the gravel bridge the airspace above the top of the flashing. When this occurs the effective freeboard of the through-wall flashing is reduced and water can have easy entry to the interior of the structure. Care in material selection is important because fractured stones can cut the flashing. Also, the weight of the gravel may stretch and tear the flashings, particularly at shelf angle bolts or at lintels where the flashing is not continuously supported. A number of proprietary systems also serve this function and claim to avoid the disadvantages of gravel.

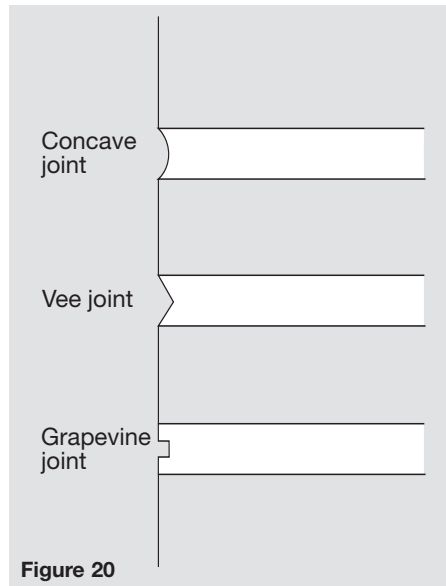

GLAZED BRICK

Because water cannot escape through the face of a glazed brick, the evaporation of water through the face of the masonry is severely limited and large amounts of water may be trapped in the veneer. This reservoir of water may affect the durability of the masonry and it must be eliminated. The loss of surface evaporation must be balanced by designing an air space at least two inches wide and incorporating open head joint weepholes at the bases of air spaces and open head joint vents at the tops of air spaces. Individual weepholes and vents should be no more than 24" apart horizontally. Obviously, it is mandatory that the air space be kept clean so that air can move freely.

MORTAR

There are two rules for mortar selection:

- 1) No one mortar is best for every purpose and
- 2) Use the weakest mortar type that will do the job.

Portland cement/hydrated lime mortars provide the best resistance to water penetration and Type “N” Portland cement/lime mortars provide the greatest water penetration resistance. Type “S” mortar may be used where greater flexural tensile strength is important; primarily where bending

stresses may be high. Type “S” mortars may be helpful when floating is a problem or when the bricks have a very low initial rate of absorption (suction). Type “S” mortars have lower water penetration resistance, are not as workable, and are more expensive than Type “N” mortars.

JOINT TYPES

The configuration of the mortar joint affects the resistance of the joint to water penetration (**Figure 20**). Concave, vee, and grapevine joints provide the highest resistance to water penetration. All other joint profiles should not be specified for exterior work.

WORKMANSHIP

STORAGE OF MATERIALS

All masonry materials, including the masonry units, cement, lime, sand, coloring pigments, water, ties, and anchors, must be stored off of the ground to prevent damage, contamination, or absorption of water. It is particularly important to cover the mortar materials to prevent hydration and to cover the masonry units and sand to avoid water absorption and freezing during cold weather.

WEATHER EXTREMES

When it is very hot or very cold, special care must be taken during construction. Also, temperature extremes are exaggerated when it is windy.

When it is hot and dry, mortar readily loses water to evaporation, quickly becomes unworkable, and loses its ability to bond to any masonry unit. Mortars with the ability to retain water, such as mortars containing hydrated lime, should be used. If a brick has a field measured initial rate of absorption (suction) in excess of 30 grams, this loss of bonding ability is accelerated. In hot, dry conditions, these brick may have to be wet before laying. Immersing a cube of brick in water the day before laying or use of perforated hoses works well. The brick must be saturated but surface dry before laying.



When it is cold, the bricks and mortar components must be kept from freezing, the work must be covered with insulating blankets, and, depending upon conditions, the work may have to be enclosed and the space heated. Follow the recommendations contained in **BIA Technical Note #1**.

MIXING MORTAR

Mortar makes up about 20% of the area of the face of a wall laid with standard modular size brick. Since changes in the color of the mortar will change the appearance of a wall, consistent and accurate proportioning of mortar materials is important. This consistency and accuracy cannot be achieved by simply counting the number shovels of sand that go into the mixer. A procedure must be developed to assure that the same volume of sand is put in the mortar mixer for each batch of mortar. Cubic foot boxes and five gallon buckets are often used for this purpose. Specific requirements for mortar mixing are found in ASTM C 270, Standard Specification for Mortar for Unit Masonry.

MORTAR LIFE

Mortar becomes stiff in two ways: 1) Water evaporates and the mortar is no longer plastic and 2) the chemical reaction with water (hydration) causes the mortar to become stiff or hard. The chemical reaction reaches initial set in about two and one-half hours and unused mortar must be discarded at that time. Water may evaporate at any time and cause the mortar to become stiff and unusable. Rather than throw the mortar away, water can often be added to restore the plasticity of the mortar. This is called "retempering." Two notes of caution: Retempering may lighten the color of mortar and retempering will reduce compressive strength slightly. While any change in the color of the mortar is a concern, changes in compressive strength are usually minimal and the workability gained by the addition of water far outweighs the small loss of compressive strength when laying a veneer (a non-loadbearing wythe).

FULL HEAD AND BED JOINTS

It is vitally important that joints be full. If head and bed joints are not full of mortar, the effective thickness of the wall is reduced, thereby decreasing the water penetration resistance. Poor construction techniques often lead to unfilled joints. While specifications usually require full joints, the only sure way to get full head joints is for the specification to require that one head of each brick be buttered with mortar and the brick then be shoved into place.

CLEANING

The clays, shales, additives, and coatings used to manufacture a brick all determine how a **brick** must be cleaned. The presence or absence of a colored mortar or manufactured or natural building stones all affect how a masonry **wall** must be cleaned. Consult the manufacturer of each masonry product before establishing or accepting a cleaning method.

As time passes it becomes more difficult to remove hardened mortar, particularly when the mortar is in large lumps. Brush down the wall with a stiff bristle brush each time the scaffold is raised and at the end of each day or shift to remove large lumps. Type "N" mortars should be cleaned within fourteen days of laying the brick; Type "S" mortars within five to seven days.

The bucket and brush method is the preferred method. Pressure washers, while they may be useful for wetting and rinsing can cause immense damage if used to apply chemicals or to remove smears and spots.

Remember:

1. Never use muriatic acid.
2. Chemicals that are not acidic will not remove hardened mortar.
3. Metal tools of all types may damage the walls.
4. **Test all materials and methods thoroughly.** Allow the test areas to dry before accepting a chemical and method.

5. Always wet the wall thoroughly before applying chemicals and keep it wet – with water or the cleaning chemical – during the cleaning process.
6. Rinse the wall thoroughly.

EFFLORESCENCE

Efflorescence is a deposit of soluble salts on the surface of the masonry. Without water, efflorescence cannot occur. The thrust of preventative measures for controlling efflorescence is to control water in the masonry because efflorescence is only the symptom of the underlying problem – the presence of water. In most cases, these salts are extremely soluble in water and acids or special chemicals are not needed to remove them; only an absence of water and the passage of time are needed.

New buildings sometimes become stained with efflorescence. This staining is called new building bloom and is usually the result of water entering unprotected walls during construction, but may also be caused by the water in mortar or grout. New building bloom is best handled by waiting for the building walls to dry over a heating or cooling season and then allowing rains to wash the salts from the walls.

The appearance of efflorescence in older buildings is a symptom of a change in the way that the structure handles water. Eliminating the flow of water into the masonry will solve problems with efflorescence.

A common time for efflorescence is in later winter or early spring. This happens because water tends to remain in walls for a long time at this time of year – there is no extra heat to evaporate the water – and the water has a long contact time with the building components. Thus, chemicals that might be considered "insoluble" in water reveal their slight solubility because of the long contact times. Again, the solution is to deny water access to the walls. Because the location of the dew point is moved, efflorescence may also appear after HVAC system change over.



Corporate Office

Glen-Gery Corporation
1166 Spring Street
P O Box 7001
Wyomissing, PA 19610-6001

Phone: (610) 374-4011

Fax: (610) 374-1622

<http://www.glengerybrick.com>

E-mail: gg@glengerybrick.com